

# HPN-6B

## ROTARY ENCODER HEAVY DUTY



- Heavy Duty
- Shaft Diameter 10 mm
- Push Pull, Line Driver
- DC 5~26V
- IP 64 / IP 65
- Cable / Connector Output

### DIMENSION

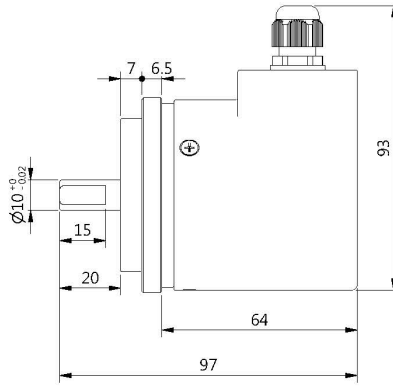
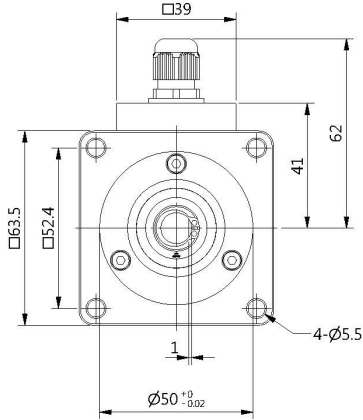

cable output

[Standard]

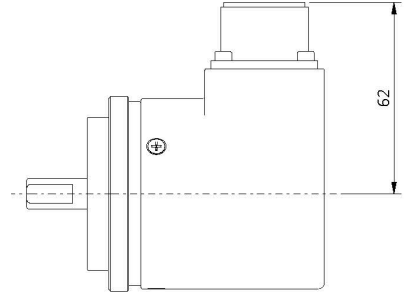

connector output

[Option] code **R7, R10**

### ELECTRICAL SPEC.

Detection System	Incremental 增量型
Output Wave 輸出波形	Square Wave 方波
Standard Number of Pulse Per Revolution 解析	5, 10, 20, 30, 40, 50, 60, 80, 100, 120, 150, 180, 200, 250, 300, 360, 400, 500, 600, 720, 800, 900, 1000, 1024, 1800, 2000, 2048, 2500, 3000, 3600, 4000, 4096, 5000
Output Phase 輸出相	ABZ phase
Electronics 電路特性	Push Pull 推挽式, Line Driver 差動式
Power Supply 供應電源	DC 5~26V
Current Consumption 消耗電流	≤ 60 mA
Output Capacity 輸出容量	Sync. Current: 20 mA, Residual Voltage: 0.5V or less
Max. Response 最大響應頻率	10K Hz ~ 100K Hz
Phase Different 相位差	A, B phase different 90°±45° (T/4±T/8), Z phase T±T/2
Wave Form Rise / Fall 波形上下時間	2 μs or less
Polarity 極性保護	Against Reverse Protection

### MECHANICAL SPEC.

Shaft Diameter 軸徑	10 mm
Shaft Loading 軸荷重	(10 ~ 1000 PPR) Axial: 5 Kg, Radial: 10 Kg (over 1000 PPR) Axial: 3 Kg, Radial: 6 Kg
Starting Torque (at 25°C) 起動轉矩	Without shaft seal: 260 gf-cm or less; With shaft seal: 400 gf-cm or less
Max. Speed 最大機械容許速度	6,000 rpm; 2,000 rpm for IP 65
Vibration 震動	10g (10±1,500 Hz)
Shock 衝擊	20g per 11 ms
Cable 電線	Ø5.4, 100 cm long
Weight 重量	≤ 500g

### ENVIRONMENTAL SPEC.

Operating Temp. / Humidity 操作溫度/濕度	-10°C ~ 60°C, RH 35% ~ 90% (No Condensation)
Storage Temp. 儲存溫度	-20°C ~ 80°C
Protection 保護等級	IP 64: dust & dripping proof IP 65(option): with Shaft Seal

### ORDERING INFORMATION

HPN-6B-	<input type="text"/>	A-	<input type="text"/>	-	<input type="text"/>	-	<input type="text"/>
	Pulse per Revolution 解析		Electronics 電路特性		Connector 連接器		Protection 保護等級
	5, 10, 20, 30, 40, 50, 60, 80, 100, 120, 150, 180, 200, 250, 300, 360, 400, 500, 600, 720, 800, 900, 1000, 1024, 1800, 2000, 2048, 2500, 3000, 3600, 4000, 4096, 5000		P: Push Pull *H: Line Driver		*R7: Radial 7 pin male connector *R10: Radial 10 pin male connector		*K1: IP 65 *OPTION



● TEL: +886 2 2226-3867 ● FAX: +886 2 2226-2011 ● E-mail: [sales@hontko.com.tw](mailto:sales@hontko.com.tw)

买原装正品 找杭州蔚联 0571-86985191